

Area Gripping Systems FMCB

Sealing element: Sealing foam or suction cups

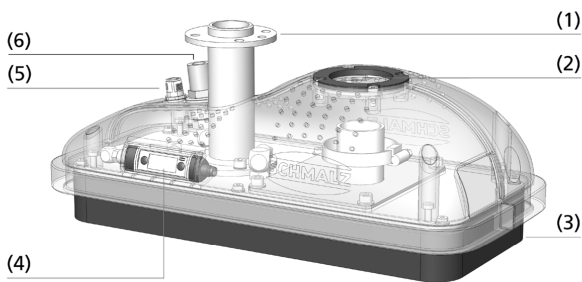

Area Gripping Systems FMCB



System design Area Gripping Systems FMCB



Area gripping systems FMCB when handling cardboard boxes

Suitability for industry specific applications

Application

- Gripping system with low weight for operation with external vacuum generation and for handling workpieces in the area of intralogistics
- Perfect for stationary handling tasks with collaborative robots
- Palletizing and depalletizing cardboard boxes

Design

- Modular gripper with 3D-printed housing
- Flange connection (1) suitable for common collaborative robots
- Connection piece (2) for external vacuum generation
- Flexible sealing foam with adhesive film or suction cups (3)
- Vacuum switch VSi (4) for system monitoring
- Compressed air connection (6) and electrical connection M12-8 (5)

Product highlights

- Area gripper suitable for HRC operation, as it meets the requirements of ISO TS 15066
- Direct, easy access to the device data via NFC interface using a smartphone
- High effective payload despite light, dynamic geometry thanks to additive manufacturing (3D printing)
- Innovative communication technology enables easy integration of the gripper in Industry 4.0 environment

Area Gripping Systems FMCB

Sealing element: Sealing foam or suction cups

Designation code Area Gripping Systems FMCB

FMCB	-	SW	-	150	-	297	-	3R
1		2		3		4		5
54	-	SPB2 40 P	-	VSi				
6		7		8				

1 – Abbreviated designation

Code	Version
FMCB	FMCB

2 – Valve technology

Code	Type
SW	Flow restrictor

3 – Nozzle diameter

Code	Diameter in mm
110...150	ø 1.1 to 1.5

4 – Length

Code	Length in mm
297	297
300	300

5 – Suction rows

Code	Number
3R	3 suction rows

6 – Hole spacing

Code	Spacing in mm
18	18
54	54

7 – Sealing element

Code	Type
O20	Sealing foam (height = 20)
SPB2 40 P	Suction cup (ø 40)

8 – Product addition

Code	Type
VSi	Vacuum and pressure switch

The large-area gripping system FMCB is delivered as a ready-to-connect product.

Ordering data Area Gripping Systems FMCB

Type	Part no.
FMCB-SW110 300 3R18 O20 VSi	PNP 10.01.43.00002
FMCB-SW110 300 3R18 O20 VSi	NPN 10.01.43.00017
FMCB-SW150 297 3R54 SPB2 40 P VSi	PNP 10.01.43.00071
FMCB-SW150 297 3R54 SPB2 40 P VSi	NPN 10.01.43.00073

Technical data Area Gripping Systems FMCB

Type	Material type	Number of suction cells	Lift capacity (vertical) [N]	Lift capacity (horizontal) [N]	Weight [kg]
FMCB-SW110 300 3R18 O20 VSi	Foam O, Height 20 mm	45	80	350	1.350
FMCB-SW150 297 3R54 SPB2 40 P VSi	-	15	80	350	1.669

Area Gripping Systems FMCB

Sealing element: Sealing foam or suction cups

Design data Area Gripping Systems FMCB

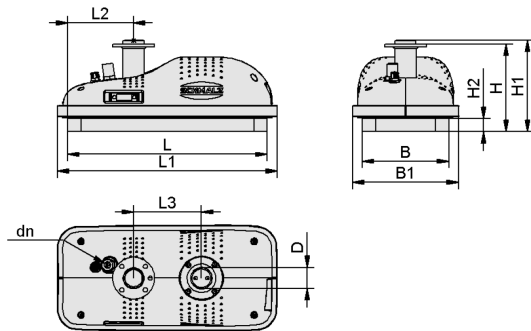

FMCB O20

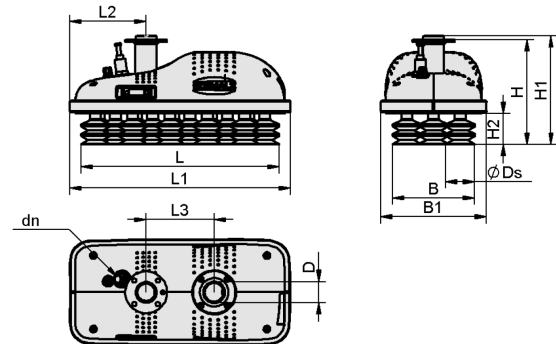

FMCB SPB2

Area Gripping Systems FMCB

Sealing element: Sealing foam or suction cups

Design data Area Gripping Systems FMCB

Type	B [mm]	B1 [mm]	dn [mm]	H [mm]	H1 [mm]	H2 [mm]	L [mm]	L1 [mm]	L2 [mm]	L3 [mm]
FMCB-SW110 300 3R18 O20 VSi	130.0	159	10	131.4	137.4	20	300	331	99.0	102
FMCB-SW150 297 3R54 SPB2 40 P VSi	123.2	159	10	158.0	164.0	47	297	331	114.4	102